



Dimension: 215 × 115 × 50mm

Features:

- AC input range selected by switch
- Small volume, low weight, high efficiency
- Protections : short circuit/over load/over voltage/over temperature
- Cooling by DC fan
- Built-in fan cooling control
- LED indicator for power on
- 100% full load burn-in test
- 2 Years warranty



SPECIFICATION

	Model	MS-500-12	MS-500-24	MS-500-36	MS-350-48
Output	DC voltage	12V	24V	36V	48V
	Voltage tolerance	± 2%	± 2%	± 2%	± 2%
	Rated current	40A	20A	13.5A	10A
	Current range	0 ~ 40A	0 ~ 20A	0 ~ 13.5A	0 ~ 10A
	Rated power	480W	480W	486W	480W
	Ripple&noise	150mVp-p	180mVp-p	240mVp-p	240mVp-p
	DC voltage ADJ. range	± 10%	± 10%	± 10%	± 10%
	Setup, rise, hold up time	600ms,20ms,24ms/230VAC,800ms,30ms,20ms/115VAC			
Input	Voltage range	90~132VAC/180~264VAC(selected by switch) 47 ~ 63Hz, 254 ~ 373VDC			
	AC current	10.5A/110V 5.5/230VAC			
	Efficiency	86%	87%	88%	89%
	Inrush current	Cold start 35A/110V, 65A/230VAC			
	leakage current	< 3.5mA/240VAC			
Protection	Overload	Rated output power 110% ~ 135% Start overload protection Protection type: hiccup mode, auto-recovery after fault condition is removed			
	Over voltage	Rated output voltage 115% ~ 135% start over voltage protection Protection type: hiccup mode, auto-recovery after fault condition is removed			
	Over temperature	≥ 55°C fan on, ≤ 45°C fan off, ≥ 85°C Start over temp protection Protection type: hiccup mode, auto-recovery after temperature become normal			
Environment	Working temp, humidity	-10°C ~ +50°C; 20% ~ 90%RH (Please refer to "derating curve")			
	Storage temp, humidity	-25°C ~ +85°C; 10% ~ 95%RH Non-condensing			
	Withstand vibration	10 ~ 500Hz, 2G 10min./1Cycle, Period for 60min, Each axes			
Safety	Withstand voltage	I/P-O/P: 1.5KVAC I/P-FG: 1.5KVAC O/P-FG: 0.5KVAC			
	Isolation resistance	I/P-O/P: I/P-FG, O/P-FG: 100M Ohms/500VDC			
Fit standard	Safety standard	Compliance to UL1012, UL60950-1, GB4943			
	EMC Standard	Compliance to EN55022, EN61000-3-2, CLASS A			
Others	Dimension	215*115*50 (L*W*H)			
	Weight	1kg/24pcs/25kg/0.049m³/1.72CUFT			
	MTBF	180K hrs min. MIL-HDBK-217F(25°C)			

Note: 1. All parameters NOT specially mentioned are measured at 230VAC input, rated load and 25°C of ambient temperature.

2. Ripple & noise are measured at 20MHz of bandwidth by using a 12" twisted pair-wire terminated with a 0.1uf & 47uf parallel capacitor.

3. Tolerance : includes set up tolerance, line regulation and load regulation.

Mechanical specification

Unit:mm

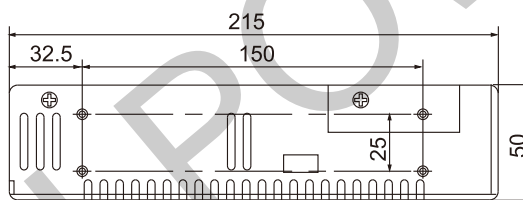
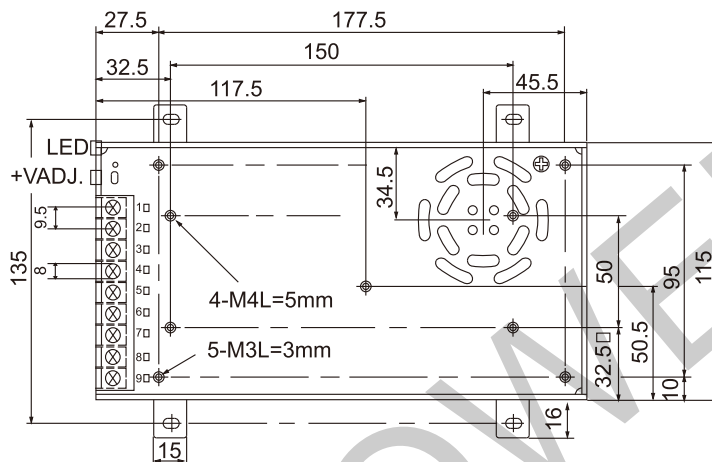

Terminal Pin No.Assignment

Pin No.	Assignment	Pin No.	Assignment
9	AC/L	4	DC OUTPUT -V
8	AC/N	1	DC OUTPUT +V
7	FG		

Block diagram

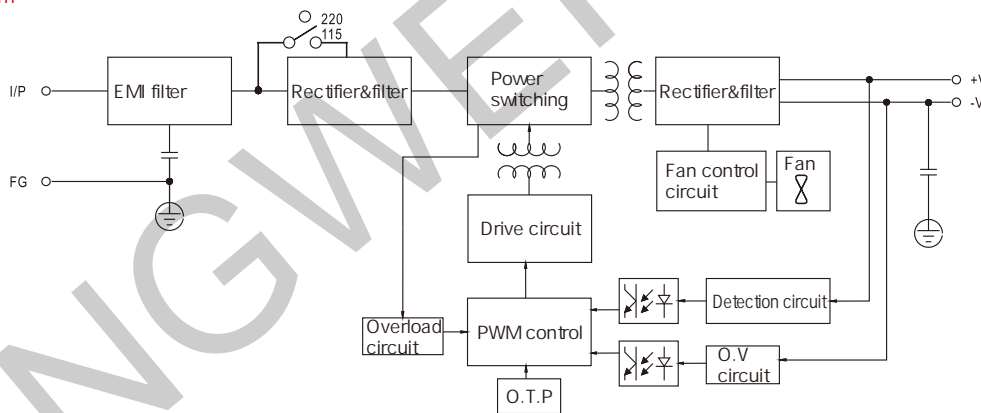

Derating curve

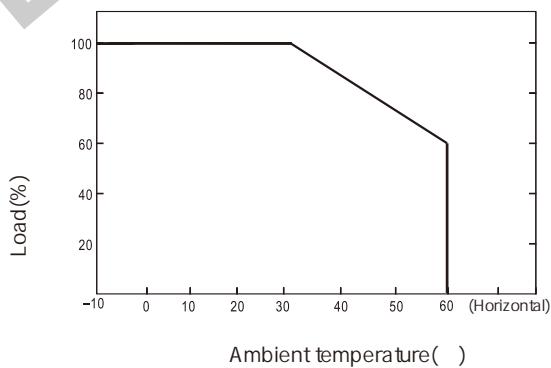

Static characteristic

