



Features:

- AC input voltage range selected by switch
- Small volume, low weight, high efficiency
- Protections : short circuit/over load/over voltage/over temp
- Cooling by free air convection
- LED indicator for power on
- 100% full load burn-in test
- 2 Years warranty

SPECIFICATION

Dimension: 199 × 98 × 38mm



Model		HS-200E-5	HS-200E-12	HS-200E-24	HS-200E-36
Output	DC voltage	5V	12V	24V	36V
	Voltage tolerance	± 1%	± 1%	± 1%	± 1%
	Rated current	30A	16.6A	8.3A	5.6A
	Current range	0 ~ 30A	0 ~ 16.6A	0 ~ 8.3A	0 ~ 5.6A
	Rated power	150W	199.2W	199.2W	201.6W
	Ripple&noise	150mVp-p	180mVp-p	240mVp-p	240mVp-p
	DC voltage ADJ. range	± 10%	± 10%	± 10%	± 10%
	Setup, rise, hold up time	1000ms,100ms,30ms/230VAC.			
Input	Voltage range	90 ~ 132VAC/180 ~ 264VAC(Selected by switch) 47 ~ 63Hz, 255 ~ 373VDC			
	AC current	4.0A/115V 2.0A/230VAC			
	Efficiency	80%	83%	85%	85%
	Inrush current	Cold start 18A/115V 36A/230VAC			
	leakage current	< 3.5mA/240VAC			
Protection	Overload	Rated output power115% ~ 150%Start overload protection Protection type: hiccup mode, auto-recovery after fault condition is removed			
	Over voltage	Rated output power115% ~ 135%Start overload protection Protection type: hiccup mode, auto-recovery after fault condition is removed			
	Over temperature	≥85°C ± 5°C(TSW1 detect on heatsink of power transistor) Protection mode: cutoff output, auto-recovery after temperature become normal			
Environment	Working temp, humidity	-10°C ~ +60°C;20% ~ 90%RH(Please refer to "derating curve")			
	Storage temp, humidity	-20°C ~ +85°C;10% ~ 95%RH Non-condensing			
Safety	Withstand vibration	10 ~ 500Hz, 2G 10min./1Cycle, Period for 60min, Each axes			
	Withstand voltage	I/P-O/P: 1.5KVAC I/P-FG: 1.5KVAC O/P-FG: 0.5KVAC			
Fit standard	Isolation resistance	I/P-O/P: I/P-FG,O/P-FG: 100M Ohms/500VDC			
	Safety standard	Fit UL1012			
Others	EMC Standard	Fit EN55022, CLASSA			
	Dimension	0.65kg 199*98*38mm (L*W*H)			
	Weight	0.65kg/30pcs/20.5kg/1.20CUFT			

Note: 1. All parameters NOT specially mentioned are measured at 230VAC input, rated load and 25°C of ambient temperature.

2. Ripple & noise are measured at 20MHz of bandwidth by using a 12" twisted pair-wire terminated with a 0.1uf & 47uf parallel capacitor.

3. Tolerance : includes set up tolerance, line regulation and load regulation.

Mechanical specification

Unit:mm

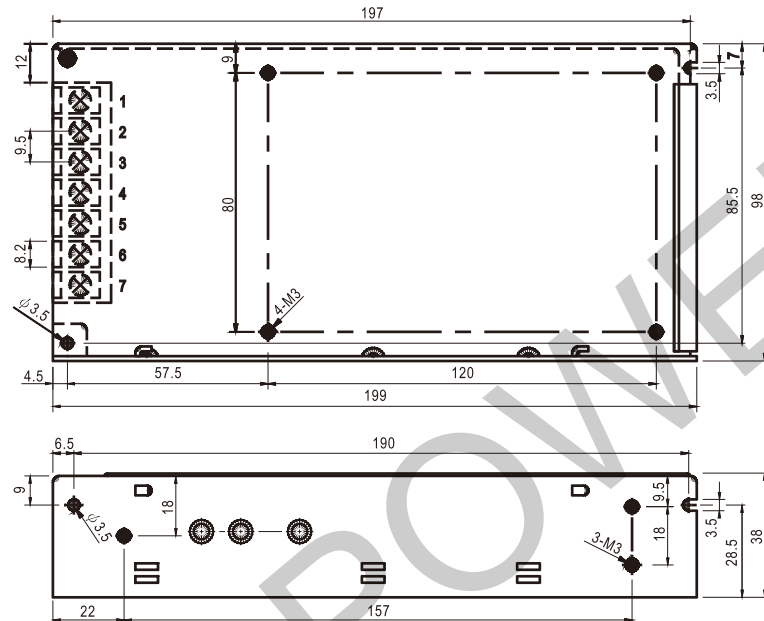

Terminal Pin No. Assignment

Pin No.	Assignment	Pin No.	Assignment
1	AC/L	4 ~ 5	DC OUTPUT -V
2	AC/N	6 ~ 7	DC OUTPUT +V
3	FG \perp		

Block diagram

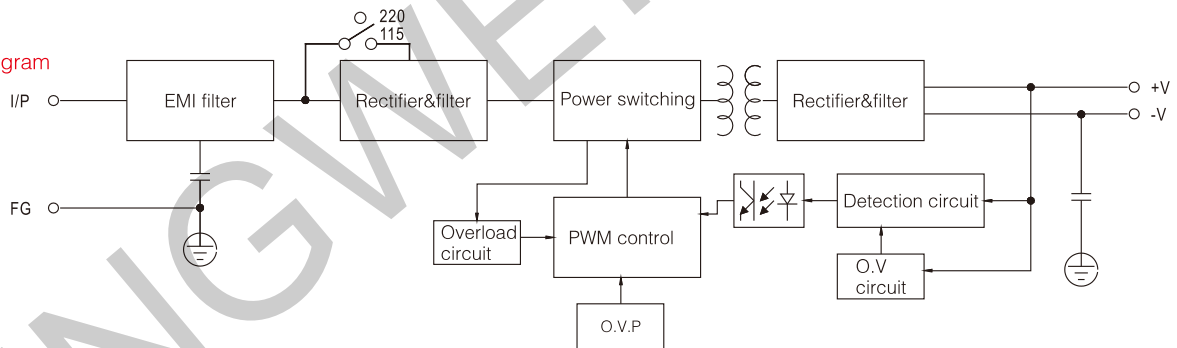

Derating curve

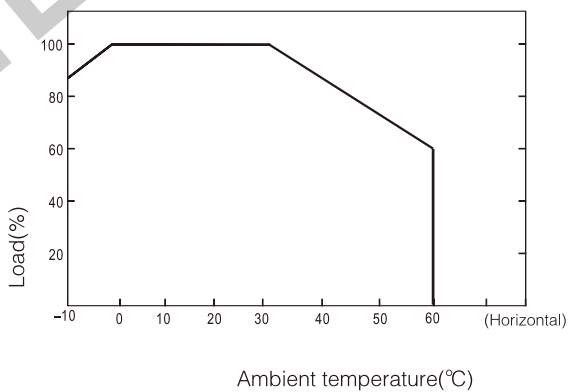

Static characteristic

